



## 1 Scope

This specification is applicable to the “Vinnic®” brand Nickel -Metal Hydride rechargeable batteries for type H80BC

Chung Pak model : H80BC

IEC model : KB156/061(KBL16/7)

## 2 Technical Parameters

Items	Units	Parameters	Conditions and others
Nominal Voltage	V	1.2	Unit cell
Capacity a.nominal capacity	mAh	80	Standard charge/discharge
b.typical capacity	mAh	90	Standard charge/discharge
Charging Method	mA	8(0.1C)	Charge at 20±5℃
a. standard charge	h	14~16	Charging temperature : 0~+45℃
b. accelerated charge	mA	16(0.2C)	Charge at 20±5℃
	h	8	Charging temperature : 10~+45℃
c. trickle charge	mA	2.4~4.0	Continuous charge at 0.03~0.05C and 0~45℃
Discharging Method	h	≥ 5	Discharge at 0.2C(16mA) to a final voltage of 1.0V at 20±5℃
a.standard discharge( 0.2C)			
b.maximum discharging current (0.5C)	min	≥ 80	Discharge at 0.5C(40mA) to a final voltage of 0.9V at 20±5℃
c.discharge at 0±2℃ (0.2C)	h	≥ 4	Discharge at 0.2C(16mA) to a final voltage of 1.0V.
Overcharge	h	≥ 4.25	At 20±5℃,charge at 0.1C(8mA) for 28 days, rest for 1~4h, then discharge at 0.2C(16mA) to a final voltage of 1.0 V.
Charge Retention	h	≥ 3.75	After standard charge, store for 28 days at 20±5℃, then discharge at 0.2C(16mA) to a final voltage of 1.0V
Cycle Life	cycle	≥ 500	IEC509 : 1988(4.4)
Storage Temperature	℃	20±10	Discharge at 0.2C(16mA) to a final voltage of 1.0V,then store for 12 months.
Storage Relative Humidity	%	65±20	
Discharge Temperature	℃	-20~+45	
Dimension a. Diameter	mm	15.6(-0.3)	
b. Height	mm	6.1(-0.6)	
Weight (approx.)	g	4.0	

When the battery open-circuit voltage is below 1.25V before first time application or after long time storage, the battery shall be charged at 0.1C(8mA) for 16h or at 0.2C(16mA) for 8h, and rested for 1~4h, then discharged at 0.2C(16mA) to a final voltage of 1.0V. Recycle for 2~3 times, then charge the battery to restore capacity for using.



### 3 Electrical Test Procedures (see below sheet)

Test Conditions: Temperature :  $20\pm 5^{\circ}\text{C}$   
Relative Humidity :  $65\pm 20\%$   
All the test batteries are samples

Items	Units	Parameters	Conditions and others	Notes
Open Circuit Voltage (OCV)	V	1.25	Within 1~4h after standard charge	
Capacity(0.2C)	mAh	80	IEC509 : 1988(4.2.1)	Note 1
Discharging method	h	$\geq 5$	Discharge at 0.2C(16mA) to a final voltage of 1.0 V at $20\pm 5^{\circ}\text{C}$	
a.standard discharge(0.2C)				
b.maximum discharging current (0.5C)	min	$\geq 80$	Discharge at 0.5C(40mA) to a final voltage of 0.9V at $20\pm 5^{\circ}\text{C}$	
c.discharge at $0\pm 2^{\circ}\text{C}$ (0.2C)	h	$\geq 4$	Discharge at 0.2C(16mA) to a final voltage of 1.0V	Note 2
Overcharge	h	$\geq 4.25$	Charge at 0.1C(8mA) for 28 days at $20\pm 5^{\circ}\text{C}$ , rest for 1~4h, then discharge at 0.2C(16mA) to a final voltage of 1.0 V.	
Charge Retention	h	$\geq 3.75$	After standard charge, store at $20\pm 5^{\circ}\text{C}$ for 28 days, then discharge at 0.2C(16mA) to a final voltage of 1.0V	
Cycle Life	cycle	$\geq 500$	IEC509 : 1988(4.4)	Note 3
	cycle	$\geq 500$	Charge at 0.2C(16mA) for 8h, rest for 1h, then discharge at 0.2C(16mA) to a final voltage of 1.0V, rest for 1h. The endurance test is considered complete when two successive capacity measurement cycles give a discharge capacity of less than 60% of the initial nominal capacity.	
Storage	$^{\circ}\text{C}$	$20\pm 10$	After the completion of the storage period, the battery shall be charged as standard charging method and then discharged as standard discharging method, the discharge capacity must meet the nominal capacity.	
	%	$65\pm 20$		
Mechanical Test	h	$\geq 4.75$	IEC509: 1988(5)	Note 4
Safety Device Operation *			IEC509:1988(4.7).The batteries shall not disrupt or burst.Leakage of electrolyte and deformation of the batteries are acceptable.	Note 5
* Warning :EXTREME CAUTION MUST BE EXERCISED WHEN CARRYING OUT THIS TEST!BATTERIES SHALL BE TESTED INDIVIDUALLY, AND IT SHOULD BE NOTED THAT BATTERIES FAILING TO MEET THE REQUIREMENT COULD DISRUPT WITH EXPLOSIVE FORCE EVEN AFTER THE BATTERY HAS BEEN DISCONNECTED FROM THE CHARGE CURRENT. FOR THIS REASON, THE TEST SHALL BE CARRIED OUT IN A PROTECTIVE CHAMBER.				



**Table 1** : Discharge capacities of discharge rates

Discharge Rate	Discharge Current (mA)	Final Voltage (V)	Minimum Capacity(mAh)	Minimum Discharge Duration(min)
0.2C	16	1.0	80	300
0.5C	40	0.9	53	80

-The batteries shall be charged at 0.1C(8mA) for 16h or at 0.2C(16mA) for 8h, then discharged at 0.2C(16mA) or at 0.5C(40mA), the discharge capacity and discharge duration shall be not less than the minimum that specified in table above.

-Five cycles are permitted for this test. The test shall be terminated at the end of the first cycle which meets the requirement.

## 4 Charge/Discharge Characteristics:

### 4.1 Charge Curves

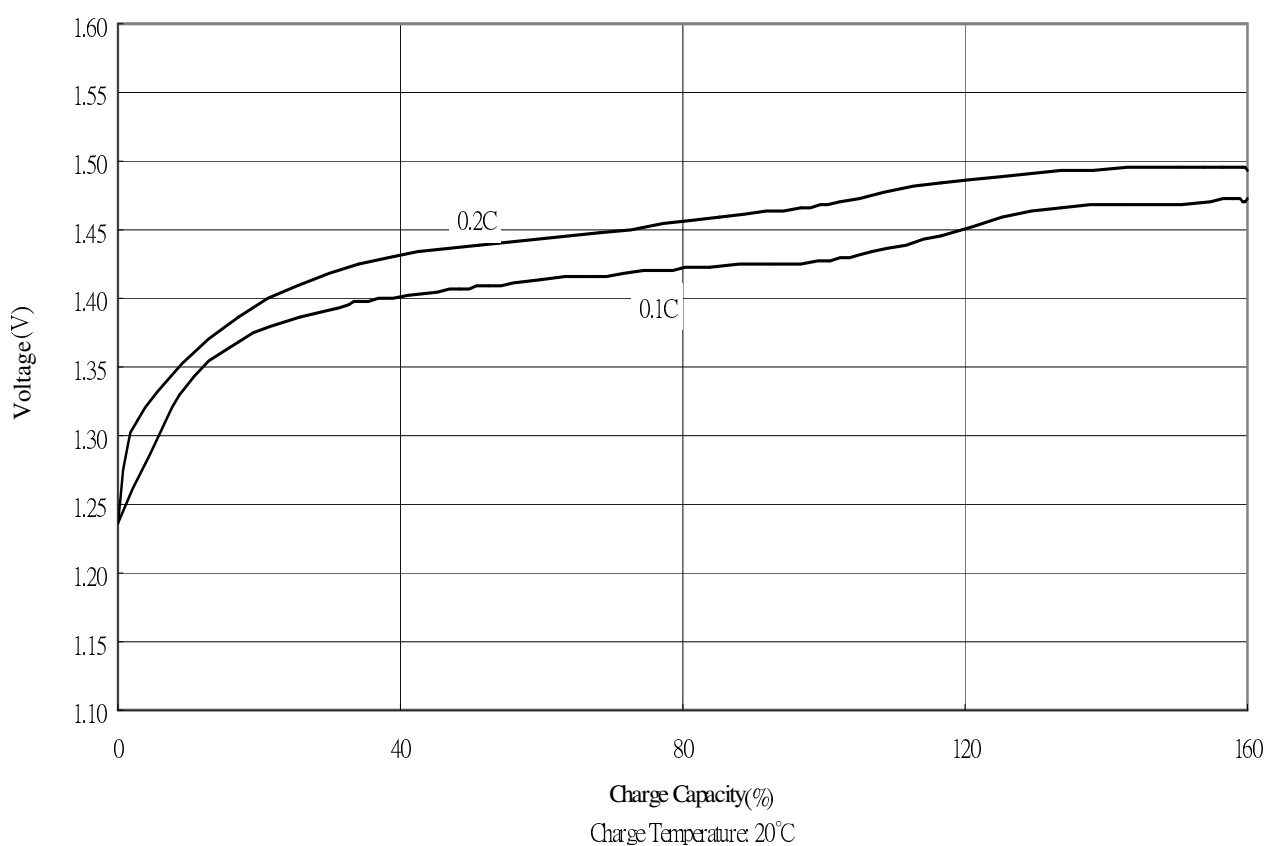



## 4.2 Discharge Curve

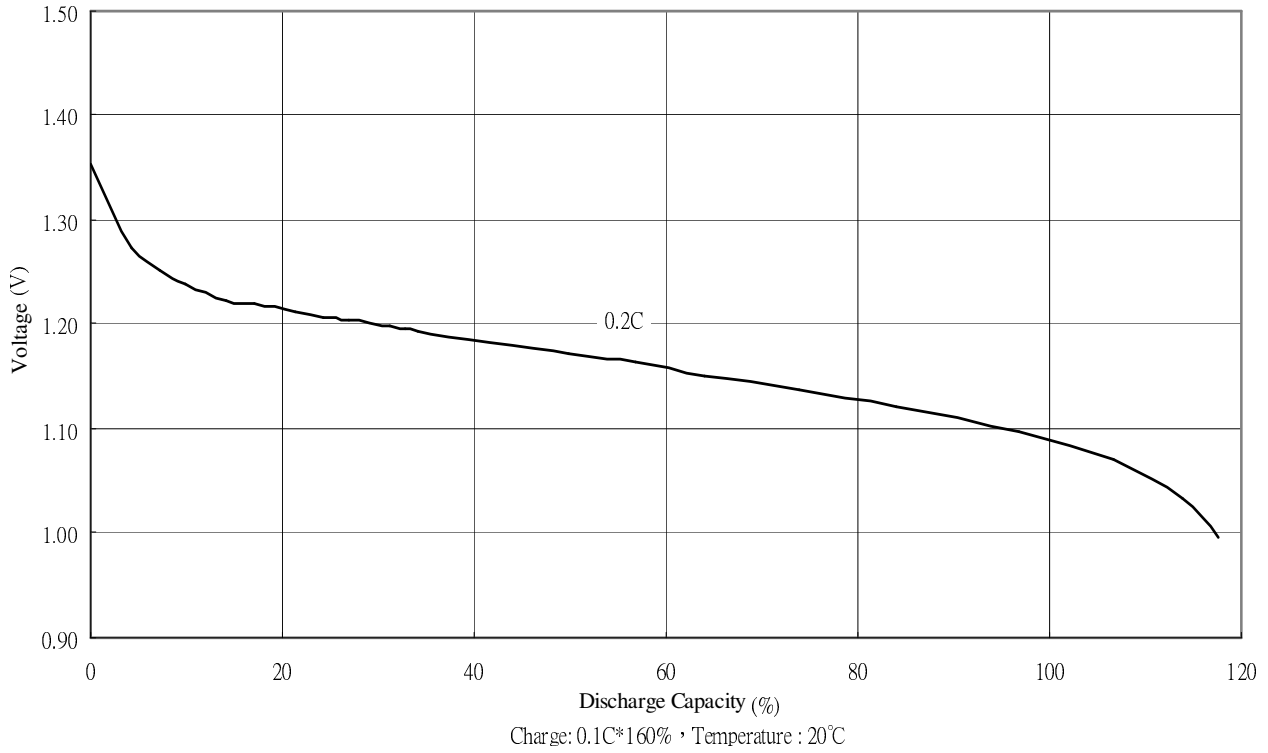

## 5 The Drawings of the Finished Battery

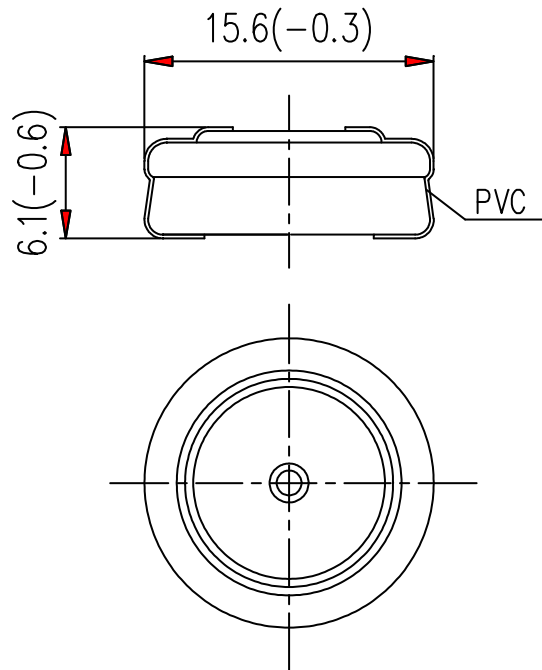

Unit: mm



## 6 Safety Instructions

<b>Warning</b>	<b>Danger</b>
Don't throw the batteries into fire or heat the batteries	This causes the batteries to ignite or disrupt
Don't solder the batteries directly	This may damage their insulating tapes and safety vents
Don't use the batteries with the $\oplus$ and the $\ominus$ electrode inverse	This damages the batteries for being over-charged or over-discharged, even may cause leakage, heat generation, disrupt, or ignition
Don't expose the batteries to water	This causes heat generation or rust
Don't connect more than 20 batteries in series	This may cause electrical shocks, leakage and heat generation
Don't disassemble or damage the external tubes of the batteries or modify the batteries (stack-up batteries) etc	This easily results in short-circuit, leakage, even or ignition
Immediately stop using the batteries if leakage, discolor or etc. with them are detected	This may cause accidents to occur
Don't drop or strongly strike the batteries	This results in leakage, heat generation, disrupt, even ignition
Be sure to charge the batteries within a temperature range from 0 to 40°C	Charge the batteries beyond the temperature range may cause leakage, heat generation, impaired performance, and shortening of service life of the batteries
Don't use old batteries with new ones or mix batteries of different charged states to use	This may cause short circuit or heat generation
Don't use our batteries with any other battery type, including dry cell or with those of different capacity or brand	Mixed-matching of batteries may result in leakage, heat generation and bursting
When more than 2 batteries are to be used together, charge them simultaneously prior to use	Did not charge them simultaneously may cause leakage or heat generation
Charge the batteries following the charging conditions that specified by Chungpak or by the charger's instructions or indicator. Never over-charge the batteries by exceeding the predetermined charging period.	This may cause leakage, heat generation, burn, even ignition and impaired performance, and shortening of service life of the batteries

## 7 Cautions

- (1) Don't connect the (+) and (-) electrode with metal or other electrically conductive materials. When carrying and storing, using special package.
- (2) Don't use the batteries in any equipment for which they were not specified.
- (3) Alkali in the electrolyte of the batteries may be harmful if it comes in contact with skin or eye. If so, wash the affected area immediately with clean water and contact a doctor.
- (4) Don't install the batteries into a sealed structure.
- (5) If the batteries are not used for a long term, the batteries shall be discharged at 0.2C(16mA) to a final voltage of 1.0V, then store at a temperature range from 10°C to +30°C and at a low humidity.
- (6) Before using the batteries, be sure to read this specification carefully. If you have any question about it, don't hesitate to contact Chungpak Battery Works LTD or a Chungpak representative.
- (7) Store the batteries out of reach of babies and small children. If children use the batteries, their guardians shall instruct them properly.



## 8 Notes

Note 1: The batteries shall be charged at 0.1C(8mA) for 16h or at 0.2C(16mA) for 8h at  $20\pm 5^{\circ}\text{C}$ , and stored for 1~4h, then discharged as specified in table 1.

Note 2: The batteries shall be charged at 0.1C(8mA) for 16h at  $20\pm 5^{\circ}\text{C}$ , and rested for 16~24h at  $0\pm 2^{\circ}\text{C}$ , then discharged at 0.2C(16mA) at  $0\pm 2^{\circ}\text{C}$ .

Note 3: The test of cycle life of the battery shall be carried out at  $20\pm 5^{\circ}\text{C}$  as specified in the table below after the battery was discharged at 0.2C(16mA) to a final voltage of 1.0V:

Cycle number	Charge	Stand in charged condition	Discharge
1	0.1C(8mA) for 16h	5h	0.2C(16mA) for 3h
2-48	0.1C(8mA) for 8h	1h	0.2C(16mA) for 3h
49	0.1C(8mA) for 8h	1h	0.2C(16mA) to 1.0V
50	0.1C(8mA) for 16h	1h	0.2C(16mA) to 1.0V

It is permissible to allow sufficient open-circuit rest time after the completion of discharge at cycle 50, so as to start cycle 51 at an exact two-week interval. A similar procedure may be adopted at cycles 100, 150, 200, 250, 300, 350, 400 and 450.

Note 4: After charging each cell with a current of 0.1C(8mA) for 16h at  $20\pm 5^{\circ}\text{C}$ , the following bump test shall be carried out at  $20\pm 5^{\circ}\text{C}$ :

-peak acceleration	390m/s <sup>2</sup> (40g)
-corresponding duration of pulse	6ms
-number of bumps	4000±40

When the bump test has been completed, each cell shall be stored for 1~4h at  $20\pm 5^{\circ}\text{C}$ . It shall then be discharged at the same temperature with a current of 0.2C(16mA) to a final voltage of 1.0V.

Note 5: The cell shall be immersed in mineral oil and forced discharged at 0.2C(16mA) to a

final voltage of 0V at  $20\pm 5^{\circ}\text{C}$ . The current shall then be increased to 1C(80mA) and maintained in direction at the same temperature of  $20\pm 5^{\circ}\text{C}$  until a steady stream of gas is observed. During, and at the end of this discharge the cell shall not disrupt or burst. Leakage and deformation of the cell are acceptable.



## **9 References**

- 9.1 IEC 509 : 1988 《sealed nickel-cadmium button rechargeable single cells》
- 9.2 SJ/T 10286-1997 《sealed nickel-cadmium button rechargeable single cells》
- 9.3 IEC 1150:1992 《Alkaline secondary cells and batteries  
Sealed nickel-cadmium rechargeable monobloc batteries in button cells design》
- 9.4 GB/T 17571-1998 《Alkaline secondary cells and batteries  
Sealed nickel-cadmium rechargeable monobloc batteries in button cells design》
- 9.5 IEC 61436:1998 《Secondary cells and batteries containing alkaline or other non-acid electrolytes-Sealed nickel-metal hydride rechargeable single cells》

## **Appendix:**

$$C=Ixt \quad (1)$$

$$I=nxC \quad (2)$$

Where

C : is the discharge capacity in ampere-hours(Ah) or milliampere-hours(mAh)

I : is the discharge current in amperes(A) or milliamperes (mA)

t : is the discharge time in hours(h)

n : is the discharge rate

$$1A=1000mA$$

$$1Ah=1000mAh$$